



# DIY 原木廚房中島

DIY Wood Kitchen Island

在您閱讀本文內容之前，您必須閱讀並同意 [DIYCOMM.COM](#) 網站的[工安聲明](#)及[版權聲明](#)。

Before reading this article, you must read and agree the terms and conditions described in the [Safety Statement](#) and [Copyright Statement](#) in [DIYCOMM.COM](#) website

## 準備工作 Preparations

- AutoCAD軟體:延續廚房改造專案,一貫使用AutoCAD3D設計家具
  - 「載重」家具設計要考慮支撐的力道問題. 一個原則,若不能用榫接穩固,就要補用木工膠. 否則會搖晃.(即鎖螺絲外,還要補膠,注意!!)
  - 實際測量家人坐下時肘高,股高,做為桌高參考. 欲置入抽屜中物件最大尺寸,做為抽屜尺寸參考. 本例中抽屜深30cm. 桌高83cm
- 材料:松木柱(4.5x 9cm), 松木厚板(4.5cm厚), 合板(僅用於內結構或非外觀件)
- 五金:
  - 陶瓷把手(ceramic handle): 可依自己喜好改用
  - 一般抽屜軌道(drawer slides)
  - 調整腳(screw-on rubber foot): 調整桌腳的高低
- 主要工具
  - 圓鋸台
  - 修邊機
  - 鑿刀

## STEP1

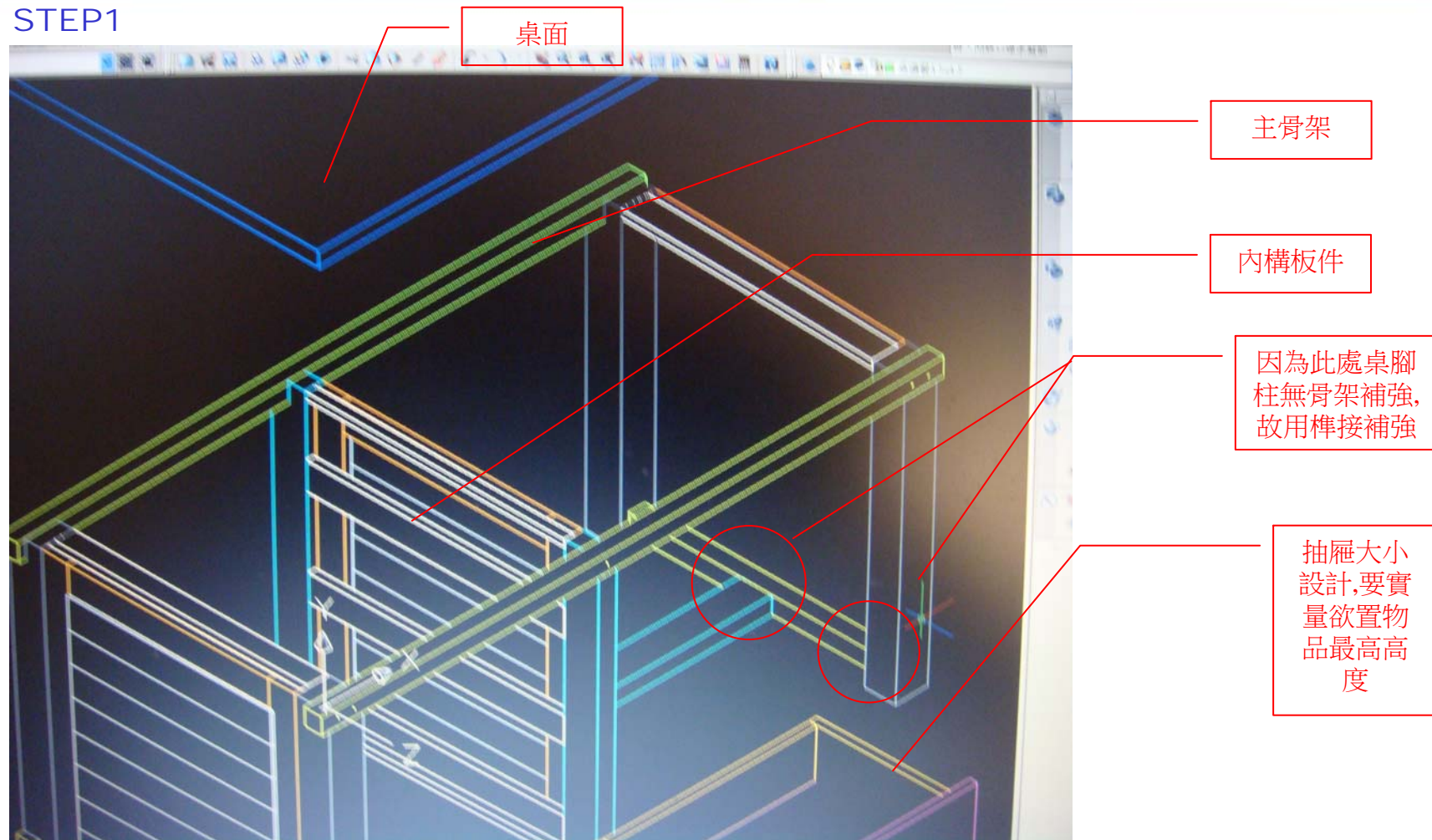

- 此廚房中島是搭配流理台的(詳「廚房流理台改造」一文).設計方式採主骨架+內構板. 一般為內構板件+ 貼面木材
- 一樣由AutoCAD3D先構圖. 為提供家人圍在中島吃飯用, 總尺寸大小約為90(寬)x190(長)x83(高)cm, 坐不會彎腰驚扭.



STEP2



抽屜上漆  
上軌道

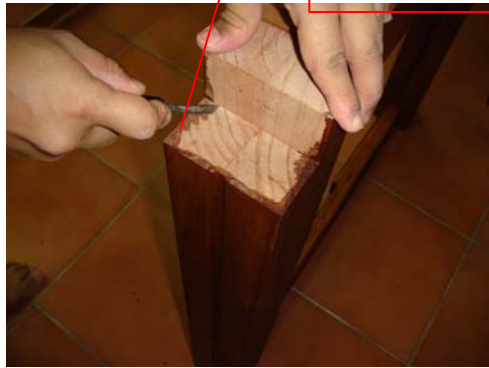

接合處修  
掉殘漆



調整抽屜  
板縫

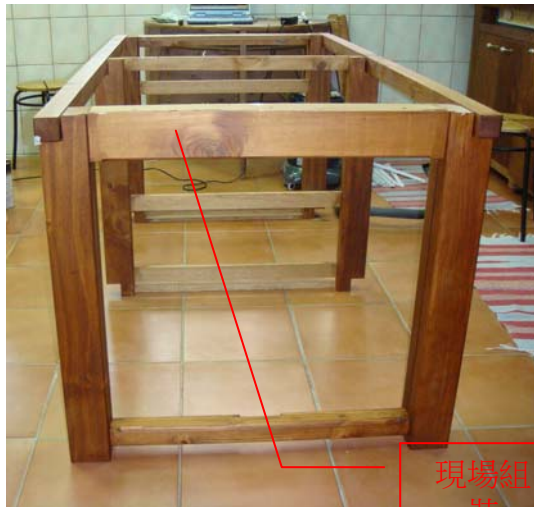

現場組  
裝



骨架鎖上  
軌道

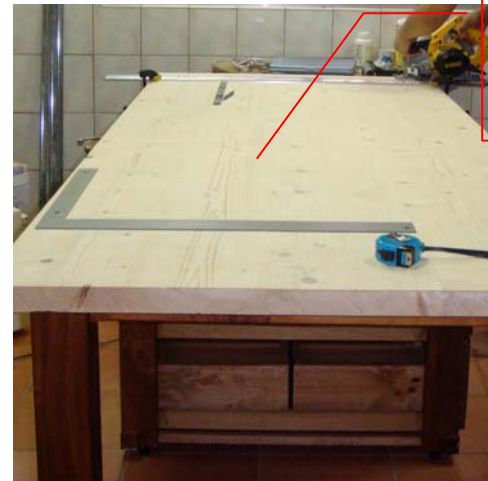

桌面太大,  
現場製作  
上漆

- 因中島太大,先製作組件(抽屜, 骨架), 上漆,至現場組裝
- 桌面太大現場做, 上漆

## STEP3

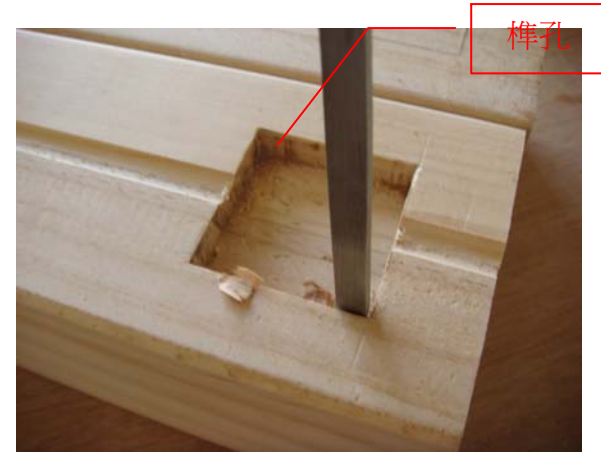

- 桌板現場上漆, 環保水性漆. 漆後不會有異味. 食物沾到桌面也不會懷疑溶毒. 大型預拼合好的木板較貴, 但很穩重漂亮.
- 有半邊桌腳因為獨立懸掛, 顧及容易鬆脫, 故做榫上膠固定



STEP4



桌板非平整,有縫



製作一反扣裝置,略L型



螺絲越鎖緊,桌板縫就越小



骨架

鎖在桌板背,反扣住骨架



完成後無縫又兼固定

- !!重要技巧!!桌板因為熱脹冷縮程度與骨架不會相同,且桌板亦非完全水平,桌板必須鎖住,卻不能用膠黏死在骨架上,所以要用倒扣法扣住骨架上,如圖.

STEP5



- 完成圖